

Low-Power, Slew-Rate-Limited RS-485/RS-422 Transceivers

General Description

The MAX485ESA is low-power transceivers for RS-485 and RS-422 communication. IC contains one driver and one receiver. The driver slew rates of the MAX485ESA is not limited, allowing them to transmit up to 2.5Mbps. These transceivers draw between 120µA and 500µA of supply current when unloaded or fully loaded with disabled drivers. All parts operate from a single 5V supply. Drivers are short-circuit current limited and are protected against excessive power dissipation by thermal shutdown circuitry that places the driver outputs into a high-impedance state. The receiver input has a fail-safe feature that guarantees a logic-high output if the input is open circuit. The MAX485ESA is designed for half-duplex applications.

Features

- Low Quiescent Current: 300µA
- -7V to +12V Common-Mode Input Voltage Range
- Three-State Outputs
- 30ns Propagation Delays, 5ns Skew
- Full-Duplex and Half-Duplex Versions Available
- Operate from a Single 5V Supply
- Allows up to 32 Transceivers on the Bus
- Data rate: 2,5 Mbps
- Current-Limiting and Thermal Shutdown for Driver Overload Protection

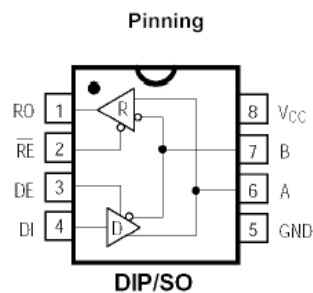

ABSOLUTE MAXIMUM RATINGS

Supply Voltage (V_{CC}) 12V
 Control Input Voltage -0.5V to ($V_{CC} + 0.5V$)
 Driver Input Voltage (DI) -0.5V to ($V_{CC} + 0.5V$)
 Driver Output Voltage (A, B) -8V to +12.5V
 Receiver Input Voltage (A, B) -8V to +12.5V
 Receiver Output Voltage (RO) -0.5V to ($V_{CC} + 0.5V$)

Continuous Power Dissipation ($T_A = +70^\circ\text{C}$)
 8-Pin Plastic DIP (derate 9.09mW/ $^\circ\text{C}$ above +70 $^\circ\text{C}$) 727mW
 8-Pin SO (derate 5.88mW/ $^\circ\text{C}$ above +70 $^\circ\text{C}$) 471mW
 Operating Temperature Ranges -40 $^\circ\text{C}$ to +85 $^\circ\text{C}$
 Storage Temperature Range -65 $^\circ\text{C}$ to +160 $^\circ\text{C}$
 Lead Temperature (soldering, 10sec) +300 $^\circ\text{C}$

DC ELECTRICAL CHARACTERISTICS

($V_{CC} = 5V \pm 5\%$, $T_A = T_{MIN}$ to T_{MAX} , unless otherwise noted.) (Notes 1, 2)

PARAMETER	SYMBOL	CONDITIONS	MIN	TYP	MAX	UNITS
Differential Driver Output (no load)	V_{OD1}				5	V
Differential Driver Output (with load)	V_{OD2}	R = 50 Ω (RS-422)	2			V
		R = 27 Ω (RS-485), Figure 4	1.5		5	V
Change in Magnitude of Driver Differential Output Voltage for Complementary Output States	ΔV_{OD}	R = 27 Ω or 50 Ω , Figure 4			0.2	V
Driver Common-Mode Output Voltage	V_{OC}	R = 27 Ω or 50 Ω , Figure 4			3	V
Change in Magnitude of Driver Common-Mode Output Voltage for Complementary Output States	ΔV_{OD}	R = 27 Ω or 50 Ω , Figure 4			0.2	V
Input High Voltage	V_{IH}	DE, DI, \overline{RE}	2.0			V
Input Low Voltage	V_{IL}	DE, DI, \overline{RE}			0.8	V
Input Current	I_{IN1}	DE, DI, \overline{RE}			± 2	μA
Input Current (A, B)	I_{IN2}	DE = 0V; $V_{CC} = 0V$ or 5.25V,	$V_{IN} = 12V$		1.0	mA
			$V_{IN} = -7V$		-0.8	
Receiver Differential Threshold Voltage	V_{TH}	-7V $\leq V_{CM} \leq 12V$	-0.2		0.2	V
Receiver Input Hysteresis	ΔV_{TH}	$V_{CM} = 0V$		70		mV
Receiver Output High Voltage	V_{OH}	$I_O = -4\text{mA}$, $V_{ID} = 200\text{mV}$	3.5			V
Receiver Output Low Voltage	V_{OL}	$I_O = 4\text{mA}$, $V_{ID} = -200\text{mV}$			0.4	V
Three-State (high impedance) Output Current at Receiver	I_{OZR}	0.4V $\leq V_O \leq 2.4V$			± 1	μA
Receiver Input Resistance	R_{IN}	-7V $\leq V_{CM} \leq 12V$				k Ω

DC ELECTRICAL CHARACTERISTICS (continued)

 ($V_{CC} = 5V \pm 5\%$, $T_A = T_{MIN}$ to T_{MAX} , unless otherwise noted.) (Notes 1, 2)

PARAMETER	SYMBOL	CONDITIONS	MIN	TYP	MAX	UNITS
No-Load Supply Current (Note 3)	I_{CC}	$DE = V_{CC}$		500	900	
		$RE = 0V$ or V_{CC}		300	500	μA
		$DE = 0V$				
Driver Short-Circuit Current,						
	I_{OSD1}	$-7V \leq V_O \leq 12V$ (Note 4)	35		250	mA
$V_O = High$						
Driver Short-Circuit Current,						
	I_{OSD2}	$-7V \leq V_O \leq 12V$ (Note 4)	35		250	mA
$V_O = Low$						
Receiver Short-Circuit Current	I_{OSR}	$0V \leq V_O \leq V_{CC}$	7		95	mA

SWITCHING CHARACTERISTICS

 ($V_{CC} = 5V \pm 5\%$, $T_A = T_{MIN}$ to T_{MAX} , unless otherwise noted.) (Notes 1, 2)

PARAMETER	SYMBOL	CONDITIONS	MIN	TYP	MAX	UNITS
Driver Input to Output	t_{PLH}	$R_{DIFF} = 54\Omega$	10	30	60	ns
	t_{PHL}	$C_{L1} = C_{L2} = 100pF$	10	30	60	
Driver Output Skew to Output	t_{SKEW}	$R_{DIFF} = 54\Omega$, $C_{L1} = C_{L2} = 100pF$		5	10	ns
Driver Enable to Output High	t_{ZH}	$C_L = 100pF$, S2 closed		40	70	ns
Driver Enable to Output Low	t_{ZL}	$C_L = 100pF$, S1 closed		40	70	ns
Driver Disable Time from Low	t_{LZ}	$C_L = 15pF$, S1 closed		40	70	ns
Driver Disable Time from High	t_{HZ}	$C_L = 15pF$, S2 closed		40	70	ns
$t_{PLH} - t_{PHL}$ Differential	t_{SKD}	$R_{DIFF} = 54\Omega$		13		ns
Receiver Skew		$C_{L1} = C_{L2} = 100pF$				
Receiver Enable to Output Low	t_{ZL}	$C_{RL} = 15pF$, S1 closed		20	50	ns
Receiver Enable to Output High	t_{ZH}	$C_{RL} = 15pF$, S2 closed		20	50	ns
Receiver Disable Time from Low	t_{LZ}	$C_{RL} = 15pF$, S1 closed		20	50	ns
Receiver Disable Time from High	t_{HZ}	$C_{RL} = 15pF$, S2 closed		20	50	ns
Maximum Data Rate	f_{MAX}		2.5			$Mbps$

Operation timing diagrams of MAX485ESA

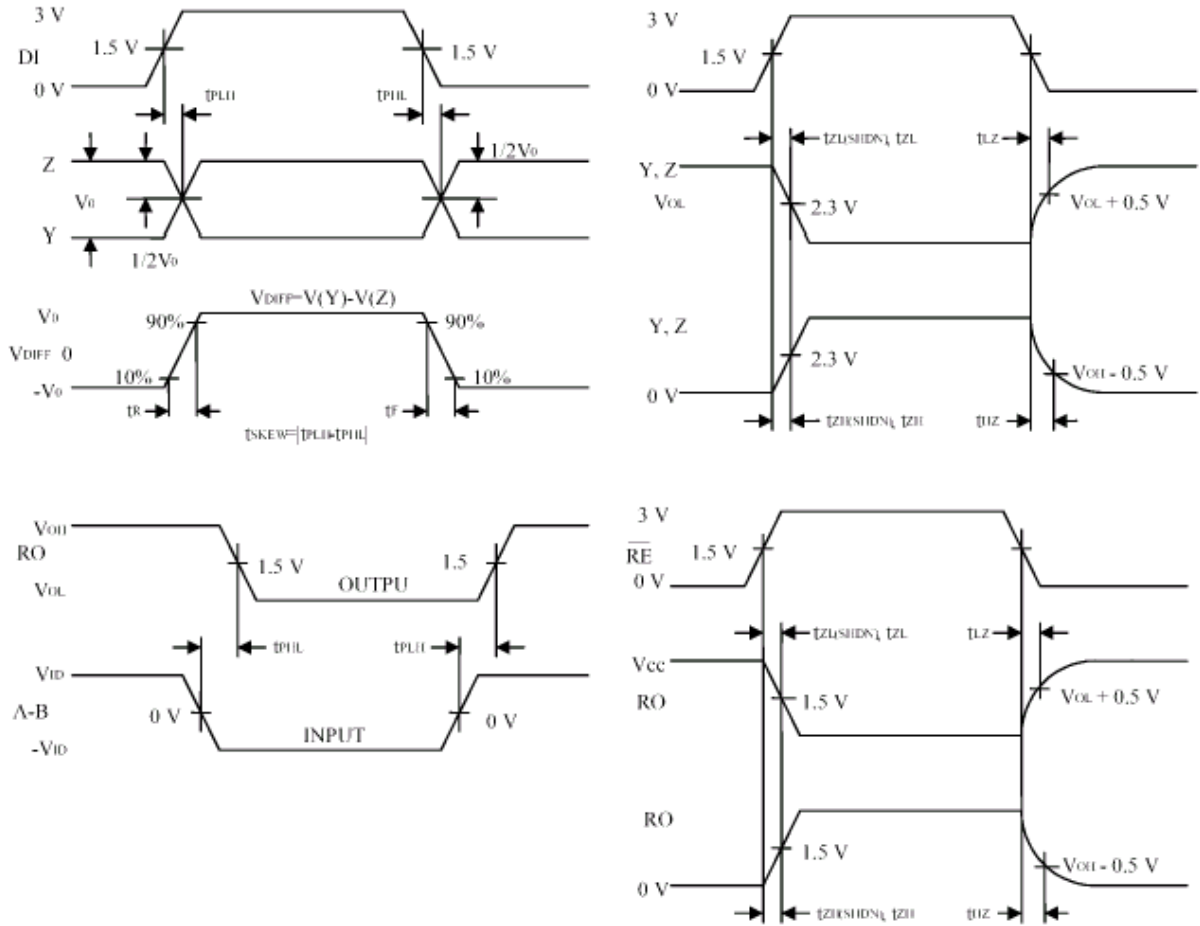
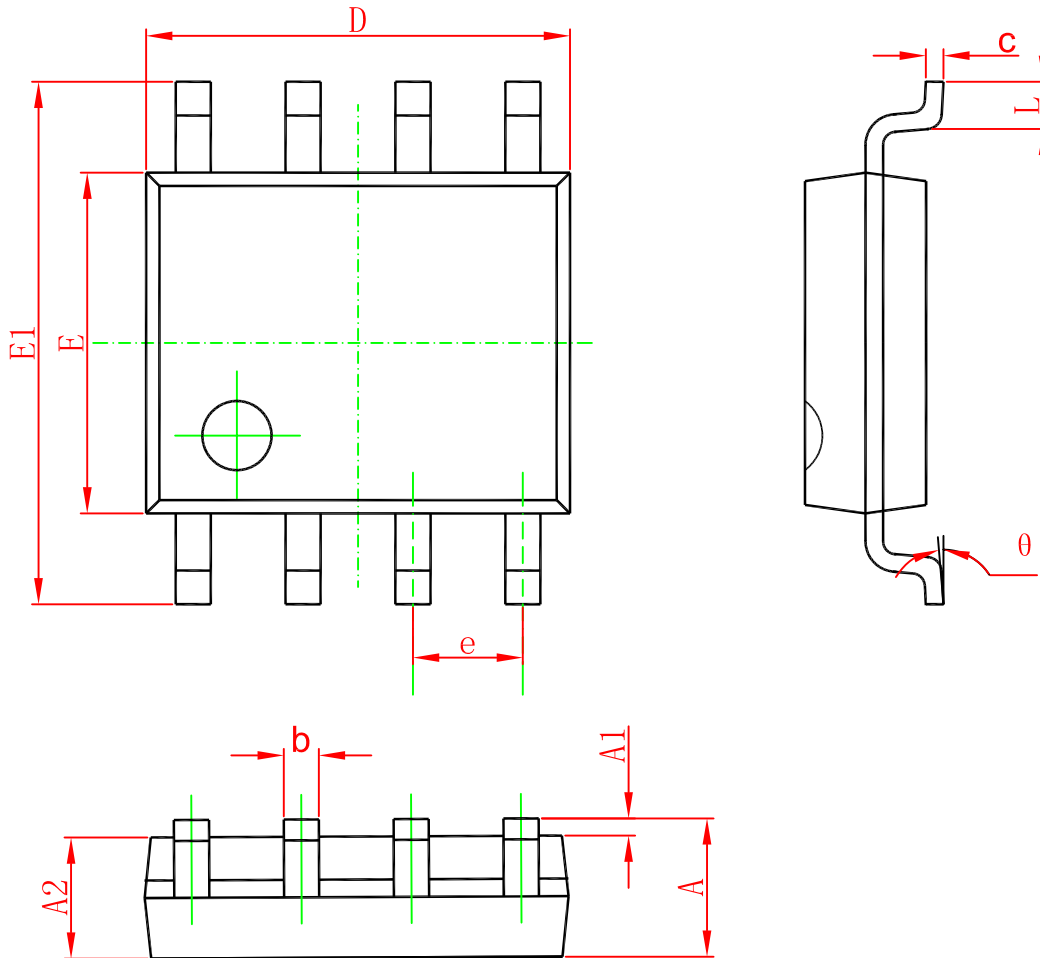

Table of MAX485ESA operation

Transmission					Receipt			
Inputs			Outputs X		Inputs			Outputs
RE	DE	DI	Z	Y	RE	DE	A-B	RO
X	1	1	0	1	0	0	+0.2V	1
X	1	0	1	0	0	0	-0.2V	0
0	0	X	Z	Z	0	0	open	1
1	0	X	Z	Z	1	0	X	Z

X-don't care
Z-high resistance

SOP-8

Symbol	Dimensions In Millimeters		Dimensions In Inches	
	Min	Max	Min	Max
A	1.350	1.750	0.053	0.069
A1	0.100	0.250	0.004	0.010
A2	1.350	1.550	0.053	0.061
b	0.330	0.510	0.013	0.020
c	0.170	0.250	0.006	0.010
D	4.700	5.100	0.185	0.200
E	3.800	4.000	0.150	0.157
E1	5.800	6.200	0.228	0.244
e	1.270(BSC)		0.050(BSC)	
L	0.400	1.270	0.016	0.050
θ	0°	8°	0°	8°