

## 1. DESCRIPTION

The Device is a monolithic integrated high voltage, high current four channel driver designed to accept standard DTL or TTL logic levels and drive inductive loads (such as relays solenoides, DC and stepping motors) and switching power transistors.

To simplify use as two bridges each pair of channels is equipped with an enable input. A separate supply input is provided for the logic, allowing operation at a lower voltage and internal clamp diodes are included.

This device is suitable for use in switching applications at frequencies up to 5 kHz.

The L293-16 is assembled in a 16 lead plastic package which has 4 center pins connected together and used for heatsinking

The L293-20 is assembled in a 20 lead surface mount which has 8 center pins connected together and used for heatsinking.

## 2. FEATURES

- 500mA OUTPUT CURRENT CAPABILITY PER CHANNEL
- 1A PEAK OUTPUT CURRENT (non repetitive) PER CHANNEL
- ENABLE FACILITY OVERTEMPERATURE PROTECTION
- LOGICAL "0" INPUT VOLTAGE UP TO 1.5 V (HIGH NOISE IMMUNITY)
- INTERNAL CLAMP DIODES

### 3. PIN CONFIGURATIONS AND FUNCTIONS

#### L293-20

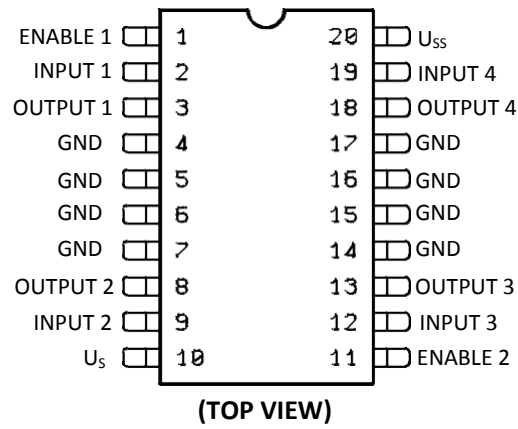

#### L293-16

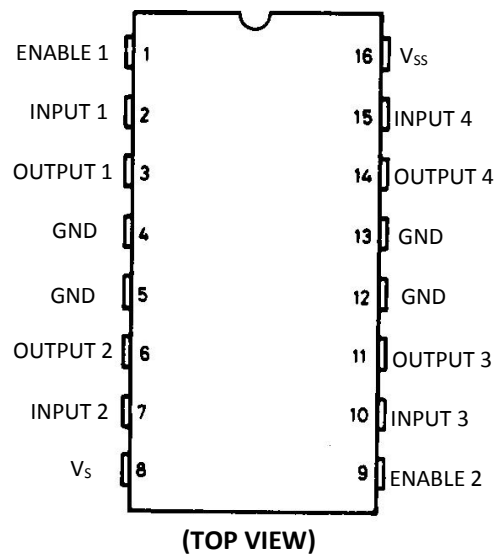

## 4. BLOCK DIAGRAM

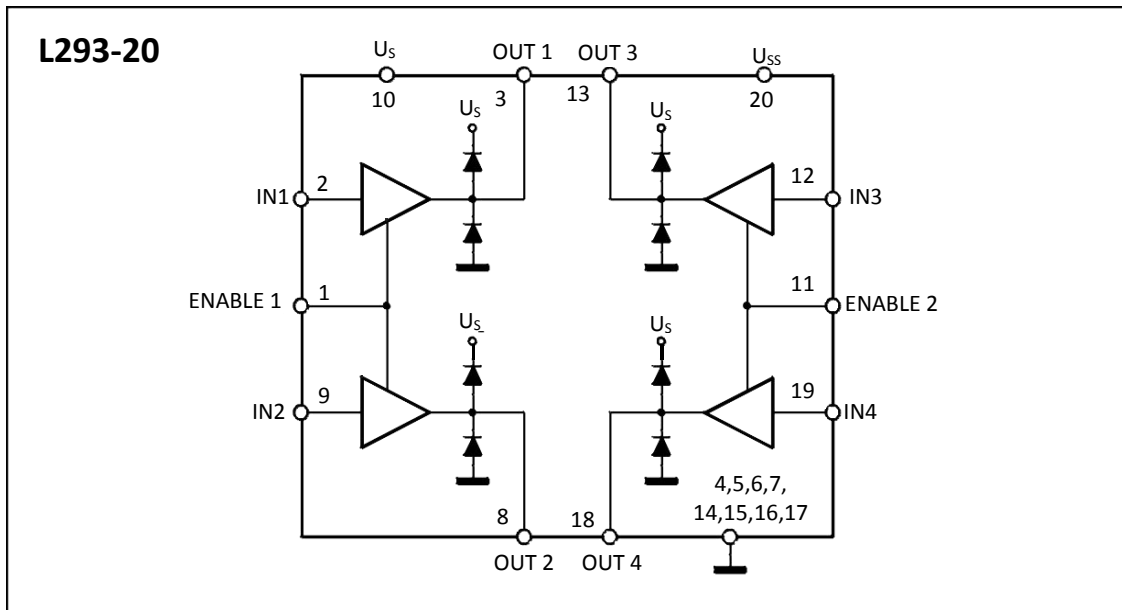

Block Diagram

## 5. SPECIFICATIONS

### 5.1. Absolute Maximum Ratings

Symbol	Parameter	Value	Unit
V <sub>S</sub>	Supply Voltage	32	V
V <sub>SS</sub>	Logic Supply Voltage	32	V
V <sub>i</sub>	Input Voltage	7	V
V <sub>en</sub>	Enable Voltage	7	V
I <sub>o</sub>	Peak Output Current (100 μs non repetitive)	1	A
P <sub>tot</sub>	Total Power Dissipation at T <sub>pins</sub> = 90 °C	3.5	W
T <sub>stg</sub> , T <sub>j</sub>	Storage and Junction Temperature	- 40 to 150	°C

### 5.2. Thermal Data

Symbol	Description	DIP16	SO-20	Unit
R <sub>th j-pins</sub>	Thermal Resistance Junction-pins	max. -	14	°C/W
R <sub>th j-amb</sub>	Thermal Resistance junction-ambient	max. 80	50 (*)	°C/W
R <sub>th j-case</sub>	Thermal Resistance Junction-case	max. 14	-	

[1] With 6sq. cm on board heatsink.

**5.3. Electrical Characteristics** (for each channel,  $V_S = 24\text{ V}$ ,  $V_{SS} = 5\text{ V}$ ,  $T_{amb} = 25\text{ }^\circ\text{C}$ , unless otherwise specified)

Symbol	Parameter	Test Conditions	Min.	Typ.	Max.	Unit
$V_S$	Supply Voltage (pin 10)		$V_{SS}$		32	V
$V_{SS}$	Logic Supply Voltage (pin 20)		4.5		32	V
$I_S$	Total Quiescent Supply Current (pin 10)	$V_i = L; I_o = 0; V_{en} = H$		3	10	mA
		$V_i = H; I_o = 0; V_{en} = H$		18	30	mA
		$V_{en} = L$			6	mA
$I_{SS}$	Total Quiescent Logic Supply Current (pin 20)	$V_i = L; I_o = 0; V_{en} = H$		47	65	mA
		$V_i = H; I_o = 0; V_{en} = H$		20	25	mA
		$V_{en} = L$		20	27	mA
$V_{IL}$	Input Low Voltage (pin 2, 9, 12, 19)		-0.3		1.5	V
$V_{IH}$	Input High Voltage (pin 2, 9, 12, 19)	$V_{SS} \leq 7\text{ V}$	2.3		$V_{SS}$	V
		$V_{SS} > 7\text{ V}$	2.3		7	V
$I_{IL}$	Low Voltage Input Current (pin 2, 9, 12, 19)	$V_{IL} = 1.5\text{ V}$			-10	$\mu\text{A}$
$I_{IH}$	High Voltage Input Current (pin 2, 9, 12, 19)	$2.3\text{ V} \leq V_{IH} \leq V_{SS} - 0.6\text{ V}$		30	100	$\mu\text{A}$
$V_{enL}$	Enable Low Voltage (pin 1, 11)		-0.3		1.5	V
$V_{enH}$	Enable High Voltage (pin 1, 11)	$V_{SS} \leq 7\text{ V}$	2.3		$V_{SS}$	V
		$V_{SS} > 7\text{ V}$	2.3		7	V
$I_{enL}$	Low Voltage Enable Current (pin 1, 11)	$V_{enL} = 1.5\text{ V}$		-30	-100	$\mu\text{A}$
$I_{enH}$	High Voltage Enable Current (pin 1, 11)	$2.3\text{ V} \leq V_{enH} \leq V_{SS} - 0.6\text{ V}$			$\pm 10$	$\mu\text{A}$
$V_{CE(sat)H}$	Source Output Saturation Voltage (pins 3, 8, 13, 18)	$I_o = -0.5\text{ A}$		1.4	2	V
$V_{CE(sat)L}$	Sink Output Saturation Voltage (pins 3, 8, 13, 18)	$I_o = +0.5\text{ A}$		1.2	2	V
$V_F$	Clamp Diode Forward Voltage	$I_o = 600\text{ nA}$		1.3		V
$t_r$	Rise Time (*)	0.1 to 0.9 $V_o$		250		ns
$t_f$	Fall Time (*)	0.9 to 0.1 $V_o$		250		ns
$t_{on}$	Turn-on Delay (*)	0.5 $V_i$ to 0.5 $V_o$		750		ns
$t_{off}$	Turn-off Delay (*)	0.5 $V_i$ to 0.5 $V_o$		200		ns

[1] See fig. 5-2.

**5.4. TRUTH TABLE (one channel)**

Input	Enable (*)	Output
H	H	H
L	H	L
H	L	Z
L	L	Z

Z = High output impedance

[1] (\*) Relative to the considered channel

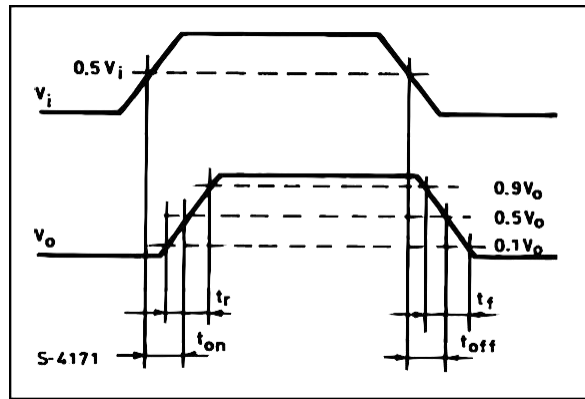

Figure 5-1: Switching Times

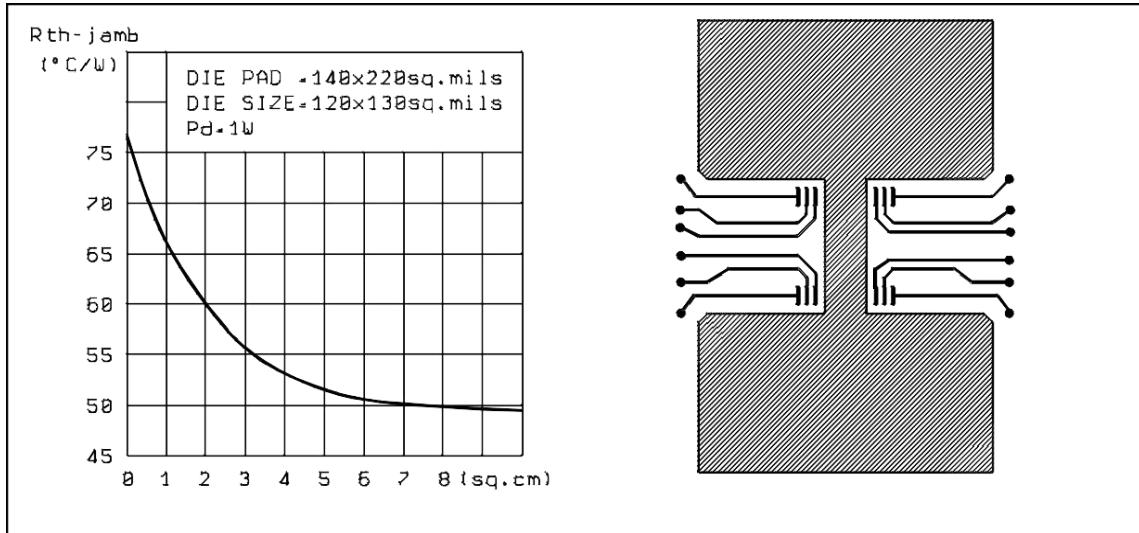

Figure5- 2: Junction to ambient thermal resistance vs. area on board heatsink

## 6. ORDERING INFORMATION

Ordering Information

Part Number	Device Marking	Package Type	Body size (mm)	Temperature (°C)	MSL	Transport Media	Package Quantity
L293-20	L293-20	SOP20	12.90 * 7.5	- 40 to 85	MSL3	T&R	1000
L293-16	L293-16	DIP16	19.05 * 6.35	- 40 to 85	MSL3	Tube 25	1000

## 7. DIMENSIONAL DRAWINGS

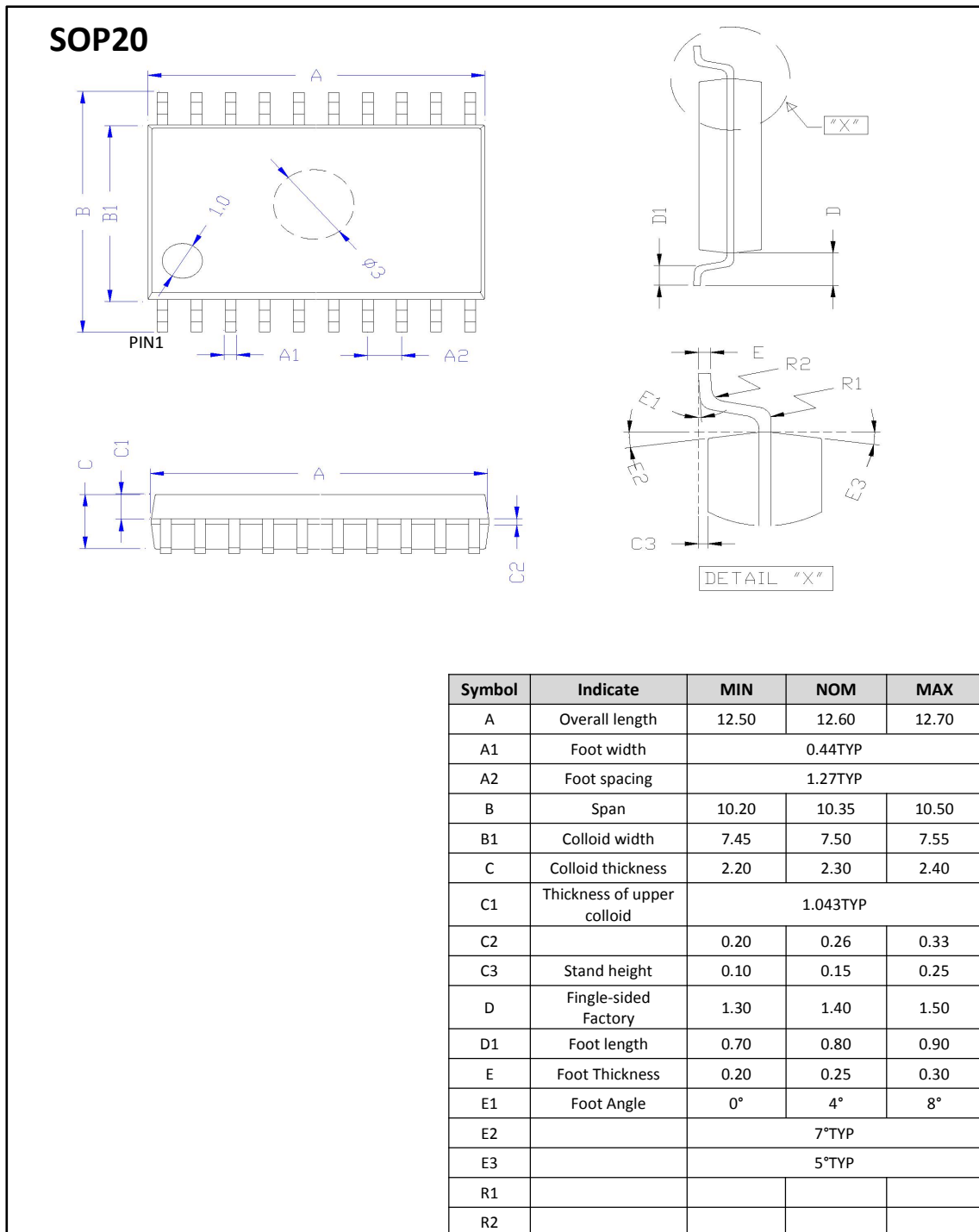

### DIP16

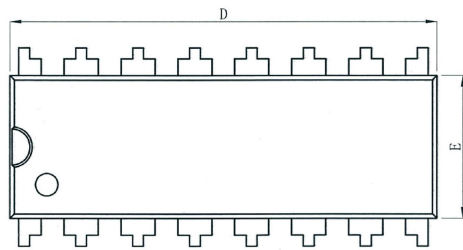
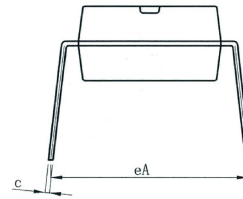
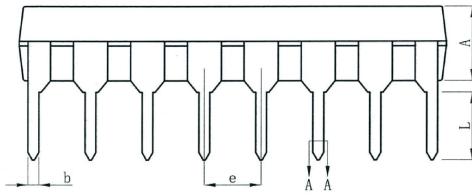

PIN1

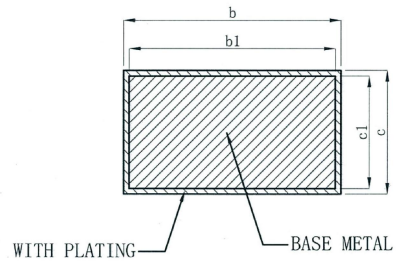

symbol	millimeter		
	Min	Nom	Max
A	3.20	3.30	3.40
b	0.44	---	0.53
b1	0.43	0.46	0.49
c	0.25	---	0.30
c1	0.24	0.25	0.26
D	18.95	19.05	19.15
E	6.25	6.35	6.45
e	2.54BSC		
eA	8.30	8.80	9.30
L	3.00	---	---