

# LM317

## HIGH CURRENT 1.3V TO 37V ADJUSTABLE VOLTAGE REGULATOR

### DESCRIPTION

The UTC **LM317** is an adjustable 3-terminal positive voltage regulator, designed to supply 1A of output current with voltage adjustable from 1.3V ~ 37V.

### FEATURES

- \*Output voltage adjustable from 1.3V ~ 37V
- \*Output current in excess of 1A
- \*Internal short circuit protection.
- \*Internal over temperature protection.
- \*Output transistor safe area compensation

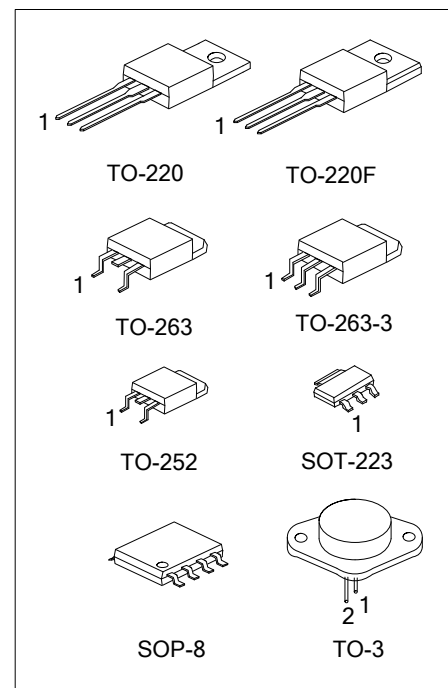

### ORDERING INFORMATION

Ordering Number		Package	Pin Assignment								Packing
Lead Free	Halogen Free		1	2	3	4	5	6	7	8	
-	LM317G-AA3-R	SOT-223	ADJ	O	I	-	-	-	-	-	Tape Reel
LM317K-TA3-T	LM317G-TA3-T	TO-220	ADJ	O	I	-	-	-	-	-	Tube
LM317K-TF3-T	LM317G-TF3-T	TO-220F	ADJ	O	I	-	-	-	-	-	Tube
LM317K-TN3-R	LM317G-TN3-R	TO-252	ADJ	O	I	-	-	-	-	-	Tape Reel
LM317K-TQ2-R	LM317G-TQ2-R	TO-263	ADJ	O	I	-	-	-	-	-	Tape Reel
LM317K-TQ2-T	LM317G-TQ2-T	TO-263	ADJ	O	I	-	-	-	-	-	Tube
LM317K-TQ3-R	LM317G-TQ3-R	TO-263-3	ADJ	O	I	-	-	-	-	-	Tape Reel
LM317K-TQ3-T	LM317G-TQ3-T	TO-263-3	ADJ	O	I	-	-	-	-	-	Tube
LM317K-T30-Y	LM317G-T30-Y	TO-3	I	ADJ	O	-	-	-	-	-	Tray
LM317K-T30-A-Y	LM317G-T30-A-Y	TO-3	ADJ	I	O	-	-	-	-	-	Tray
-	LM317G-S08-R	SOP-8	I	O	O	ADJ	NC	O	O	NC	Tape Reel

Note: 1. Pin Assignment: I:  $V_{IN}$  O:  $V_{OUT}$   
2. Pin 3 on TO-3 is case

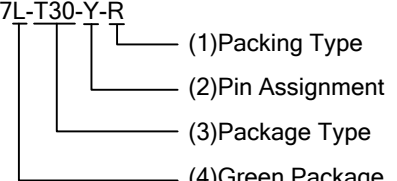
<p>LM317L-T30-Y-R</p>  <p>(1) Packing Type (2) Pin Assignment (3) Package Type (4) Green Package</p>	<p>(1) R: Tape Reel, T: Tube, Y: Tray (2) refer to Pin Assignment (3) AA3: SOT-223, TA3: TO-220, TF3: TO-220F, TN3: TO-252, TQ2: TO-263, TQ3: TO-263-3 T30: TO-3, S08: SOP-8 (4) G: Halogen Free and Lead Free, K: Lead Free</p>
---	--

## MARKING

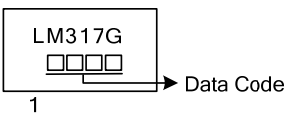
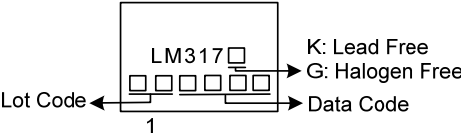
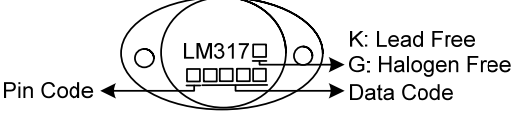
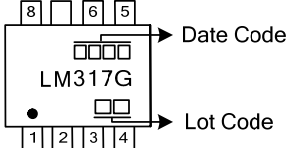
PACKAGE	MARKING
SOT-223	
TO-220 TO-220F TO-252 TO-263 TO-263-3	
TO-3	
SOP-8	

## PIN CONFIGURATION

For TO-3P

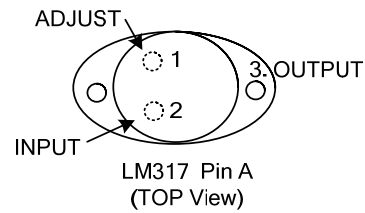
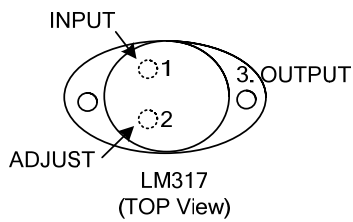

## BLOCK DIAGRAM

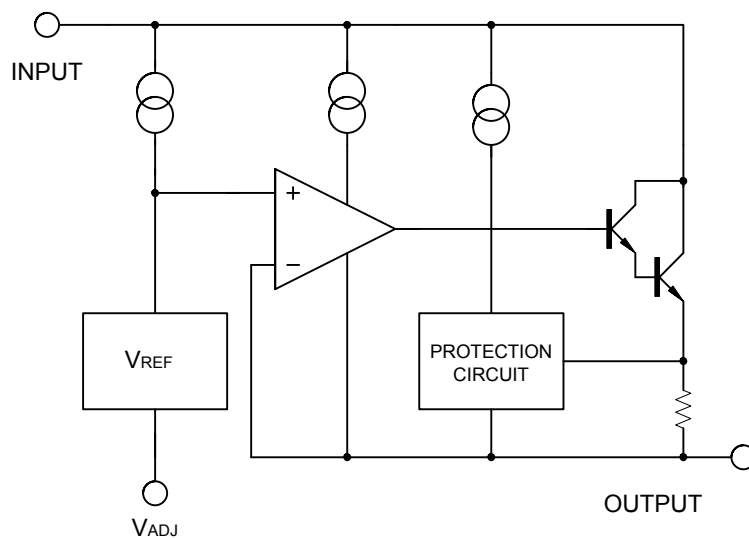

■ ABSOLUTE MAXIMUM RATINGS (T<sub>A</sub>=25°C, unless otherwise specified)

PARAMETER	SYMBOL	RATINGS	UNIT
Input - Output Voltage Difference	V <sub>IN</sub> -V <sub>OUT</sub>	40	V
Power Dissipation	P <sub>D</sub>	Internal limited	
Junction Temperature	T <sub>J</sub>	+125	°C
Operating Temperature	T <sub>OPR</sub>	-40 ~ +85	°C
Storage Temperature	T <sub>STG</sub>	-40 ~ +150	°C

Note: Absolute maximum ratings are stress ratings only and functional device operation is not implied. The device could be damaged beyond Absolute maximum ratings.

■ THERMAL DATA

PARAMETER	SYMBOL	RATINGS	UNIT
Junction-to-Ambient	θ <sub>JA</sub>	TO-252	112
		TO-220/TO-220F	65
		TO-263/TO-263-3	
		SOT-223	165
		TO-3	35
		SOP-8	190
Junction-to-Case	θ <sub>JC</sub>	TO-252	12
		TO-220/TO-263	5
		TO-263-3	
		TO-220F	7.8
		SOT-223	23
		TO-3	3
		SOP-8	4.5

■ ELECTRICAL CHARACTERISTICS

(V<sub>IN</sub>-V<sub>OUT</sub>=5V, I<sub>OUT</sub>=10mA, T<sub>A</sub>=25°C, unless otherwise specified.)

PARAMETER	SYMBOL	TEST CONDITIONS	MIN	TYP	MAX	UNIT	
Line Regulation	ΔV <sub>OUT</sub> /V <sub>OUT</sub>	3V ≦ V <sub>IN</sub> -V <sub>OUT</sub> ≦ 40V		0.01	0.04	%/V	
Load Regulation	ΔV <sub>OUT</sub>	10mA ≦ I <sub>OUT</sub> ≦ 1A		V <sub>OUT</sub> ≦ 5V	5	25	mV
				V <sub>OUT</sub> ≧ 5V	0.1	0.5	%
Adjustable Pin Current	I <sub>ADJ</sub>			50	100	μA	
Adjustable Pin Current Change	ΔI <sub>ADJ</sub>	3V ≦ V <sub>IN</sub> -V <sub>OUT</sub> ≦ 40V, 10mA ≦ I <sub>OUT</sub> ≦ 1A, P <sub>D</sub> ≦ 20W		0.2	5	μA	
Reference Voltage	V <sub>REF</sub>	3V ≦ V <sub>IN</sub> -V <sub>OUT</sub> ≦ 40V, 10mA ≦ I <sub>OUT</sub> ≦ 1A, P <sub>D</sub> ≦ 20W	1.20	1.25	1.30	V	
Temperature Stability		T <sub>MIN</sub> ≦ T <sub>J</sub> ≦ T <sub>MAX</sub>		0.7		%/V <sub>OUT</sub>	
Minimum Load Current for Regulation	I <sub>L(MIN)</sub>	V <sub>IN</sub> -V <sub>OUT</sub> =40V		3.5	10	mA	
Maximum Output Current	I <sub>O(MAX)</sub>	V <sub>IN</sub> -V <sub>OUT</sub> =40V, P <sub>D</sub> ≦ 20W	0.2	0.3		A	
RMS Noise vs. % of V <sub>OUT</sub>	eN	10Hz ≦ f ≦ 10KHz		0.003		%/V <sub>OUT</sub>	
Ripple Rejection	RR	V <sub>OUT</sub> =10V, f=120Hz		C <sub>ADJ</sub> =0	65	dB	
				C <sub>ADJ</sub> =10μF	66		80

Note: C<sub>ADJ</sub> is connected between Adjust pin and Ground.

## APPLICATION CIRCUITS

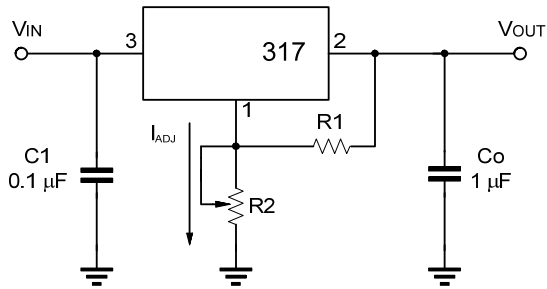

Fig.1 Programmable voltage regulator

$$V_{OUT} = 1.25V * (1 + R2/R1) + I_{ADJ} * R2$$

C1 is required when regulator is located an appreciated distance from power supply. Co is needed to improve transient response.

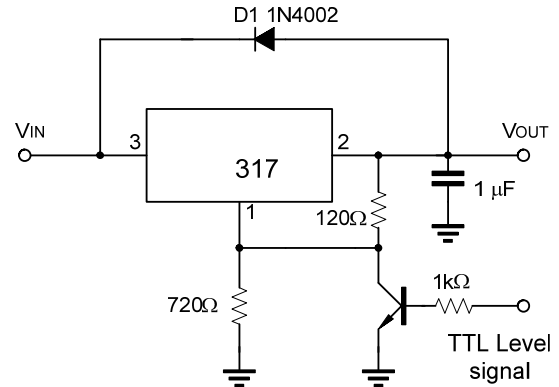

Fig.2 Regulator with On-off control

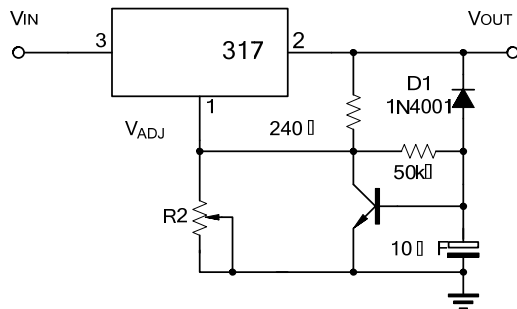
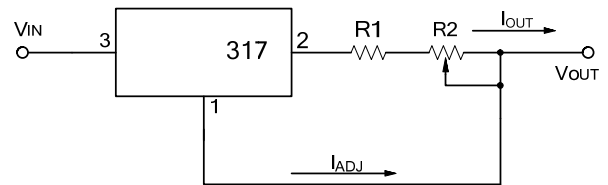

Fig.3 Soft Start Application



$$I_{O(MAX)} = \left( \frac{V_{REF}}{R1} \right) + I_{ADJ} = \frac{1.25V}{R1}$$

$$I_{O(MIN)} = \left( \frac{V_{REF}}{R1+R2} \right) + I_{ADJ} = \frac{1.25V}{R1+R2}$$

Fig.4 Constant Current Application

## TYPICAL CHARACTERISTICS

Load Regulation vs. temperature

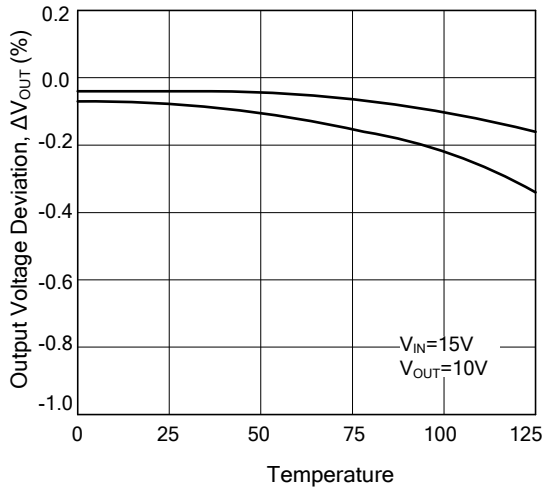

Adjustment Current vs. Temperature

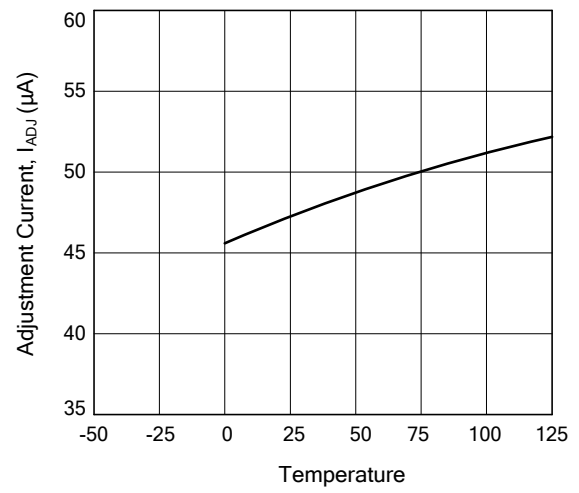

Current Limit

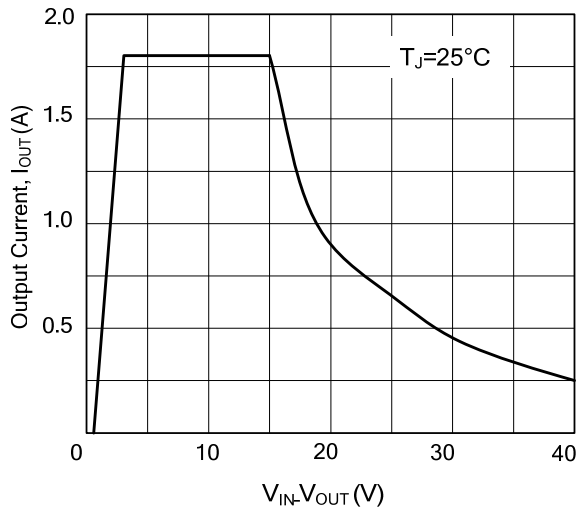

Minimum Operating Current

